



Observatory Gardens
KENSINGTON, W8



Set on the 3rd and 4th floors, with lift access, this attractive split-level apartment forms part of a well-regarded portered building in the heart of Kensington. The flat offers bright and comfortable accommodation, with generous living space, a private roof terrace and underground parking.



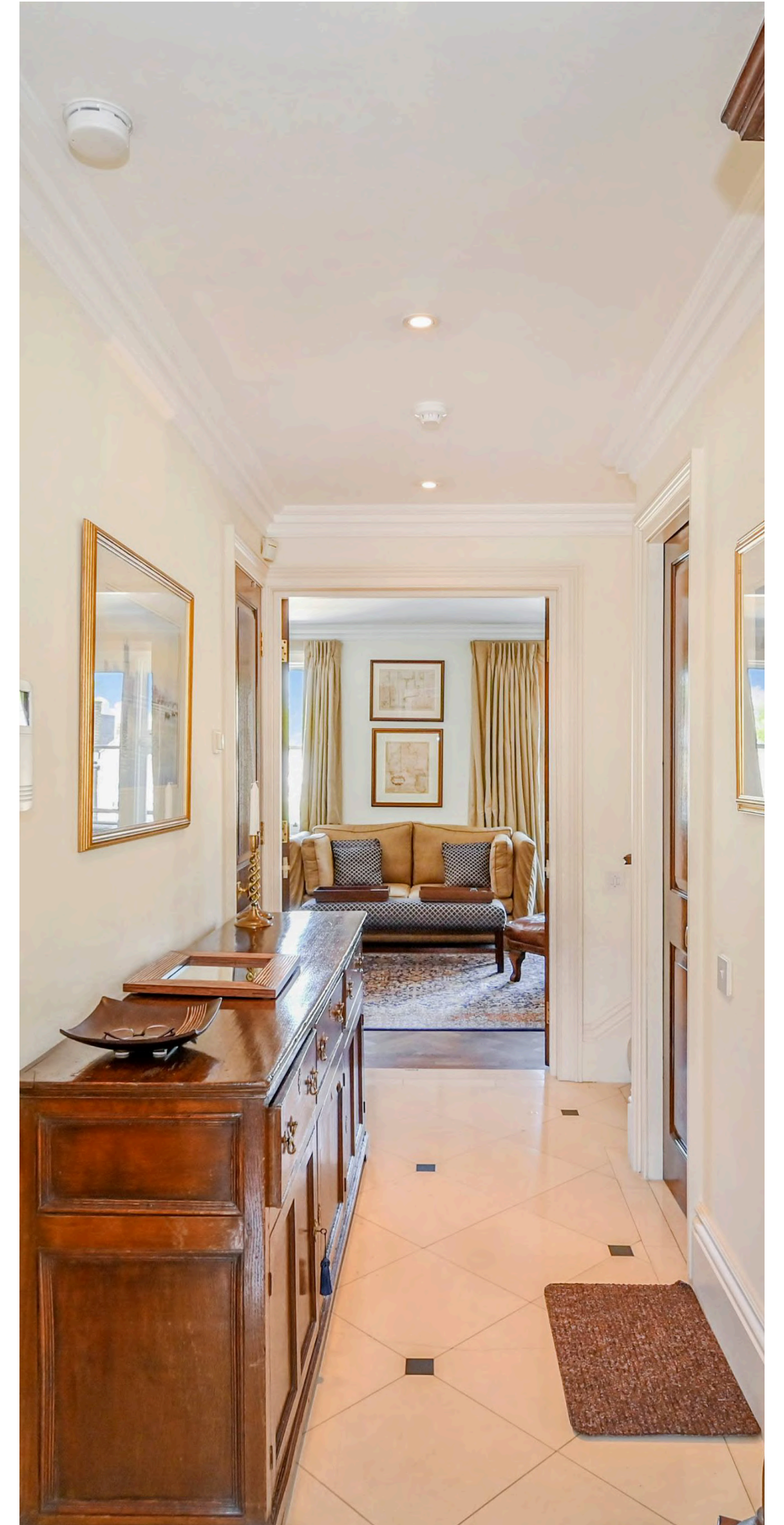



The reception room is a lovely, light space, with wood flooring, a fireplace, built-in shelving and large windows. The dining room sits just off the main living area and works well for entertaining, while the separate kitchen is neatly fitted with good storage, integrated appliances and plenty of worktop space.

Upstairs, there are three bedrooms, one of which is currently used as a study. The principal bedroom has built-in wardrobes and an en-suite bathroom, with a further bathroom serving the rest of the flat.

A further staircase leads up through a retractable glass roof that opens up onto the magnificent roof terrace with plenty of space for entertaining and incredible views above London's skyline.

Observatory Gardens is well placed for the shops, restaurants and transport links of Kensington High Street, with High Street Kensington station approximately 0.3 miles away and Notting Hill Gate station approximately 0.5 miles away. Holland Park and Kensington Gardens are also within easy reach, offering excellent nearby green space.











APPROXIMATE AREA

Approx. Total Internal Area 1303 Sq Ft / 121.05 Sq M
(Including Restricted Height Area)
Approx. Gross Internal Area 1279 Sq Ft / 118.82 Sq M
(Excluding Restricted Height Area)

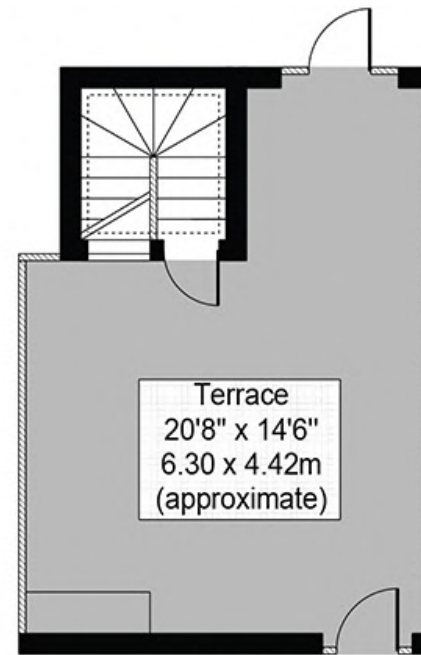

Fifth Floor

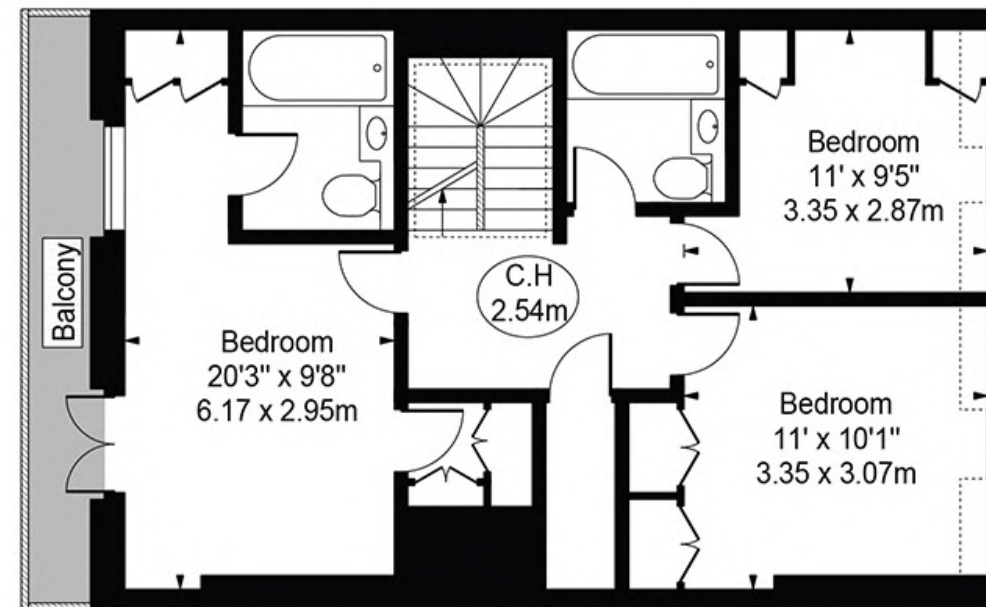

Fourth Floor

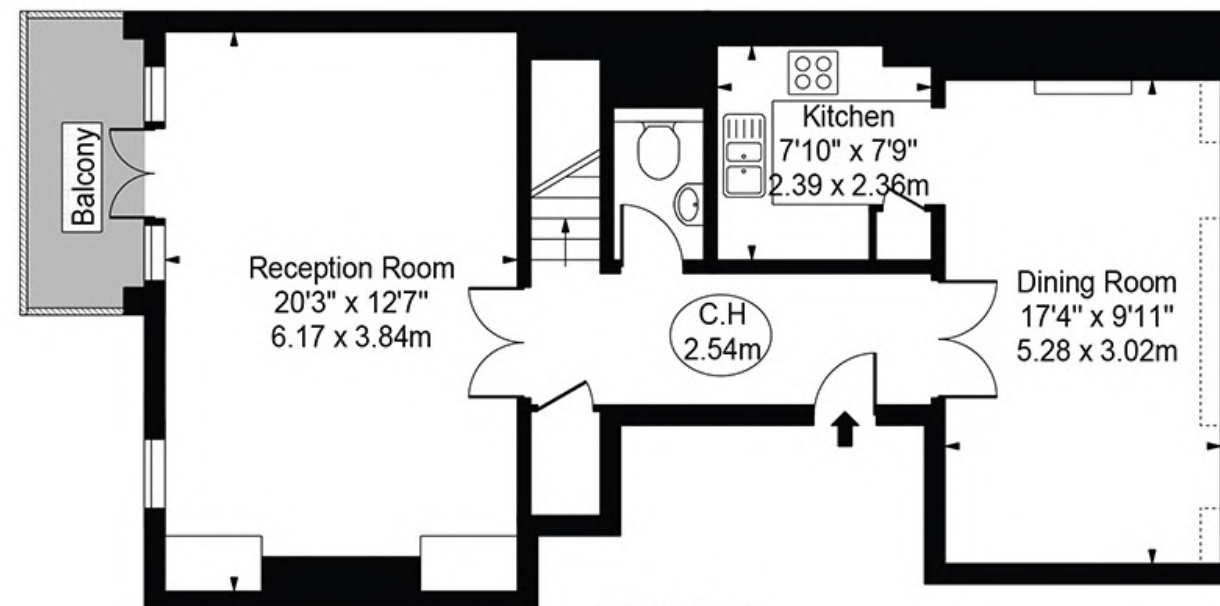

Third Floor

OBSERVATORY GARDENS

ASKING PRICE

£2,500,000

TENURE

Share of Freehold - approx.967
years remaining

Service Charge

£16,000 per annum

Ground Rent

Peppercorn

LOCAL AUTHORITY

Royal Borough of Kensington and Chelsea

COUNCIL TAX BAND

G

EPC RATING

D



105 Kensington Church Street, London W8 7LN

Tel: 0207 581 2216

sales@maskells.com

lettings@maskells.com

maskells.com